

# Robert H. Wager Co., Inc.

570 Montroyal Road  
 Rural Hall, NC 27045  
 Ph: 800-562-7024  
 Fx: 336-969-6375  
 www.wagerusa.com

UNCONTROLLED COPY  
 (FOR REFERENCE ONLY)

# AIR CHECK VALVE

3/8" AUTOMATIC SPRING CHECK VALVE  
 (SCAVENGER AIR VALVE)  
 FOR SOOTBLOWERS

MILITARY PART NUMBER - 000162NAVY

UNLESS OTHERWISE SPECIFIED

- DIMENSIONS ARE IN INCHES
- FILLETS ARE .015" TO .032" R
- BREAK EDGES .02" MAX
- TOLERANCE .02" (2 PLACE DECIMALS)

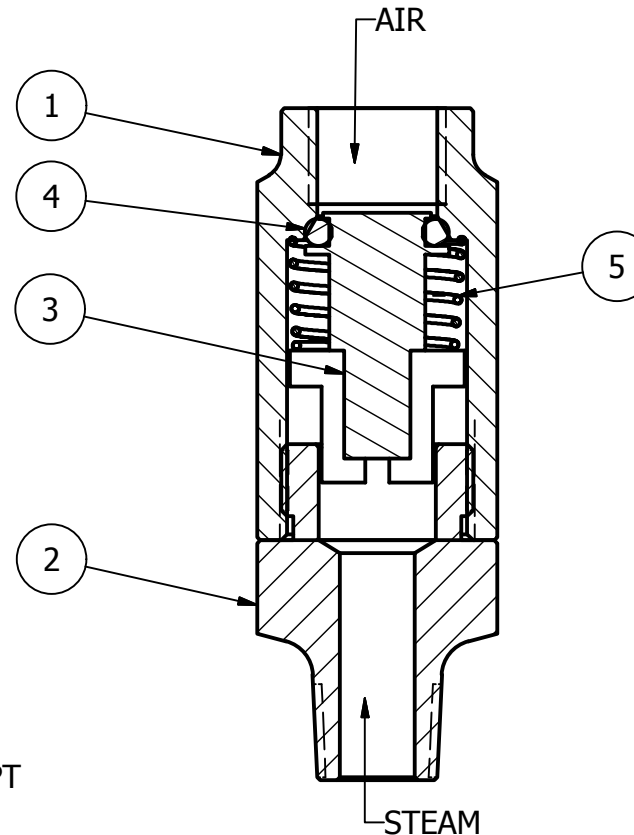
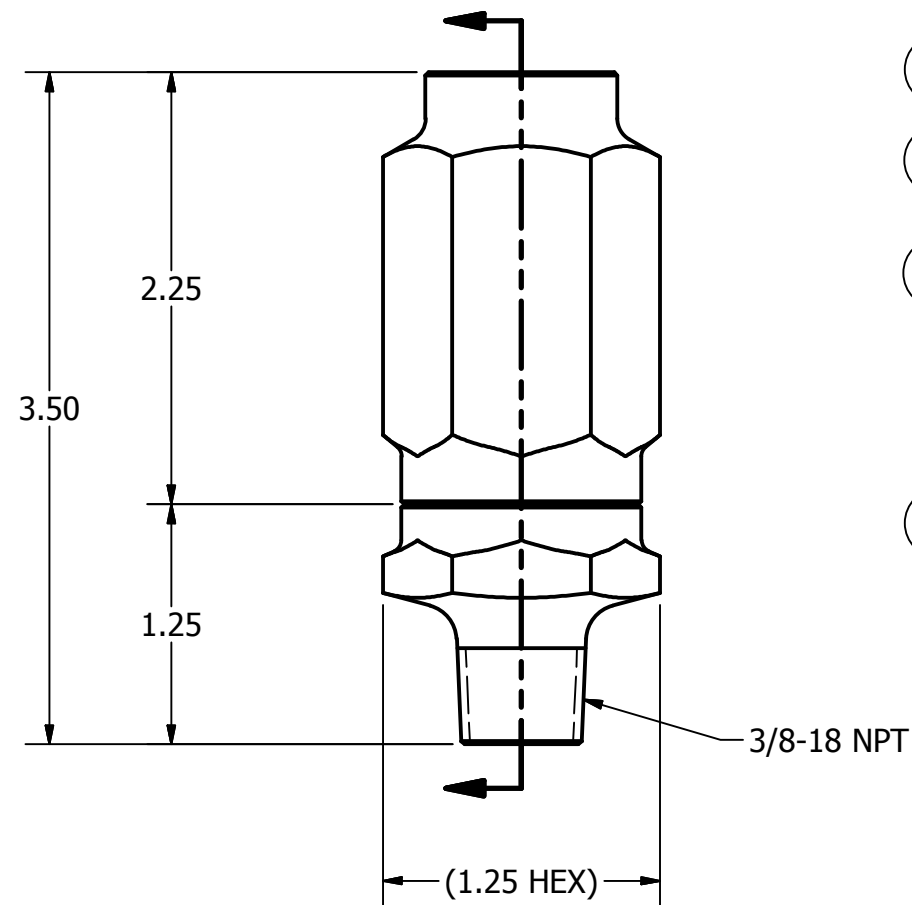
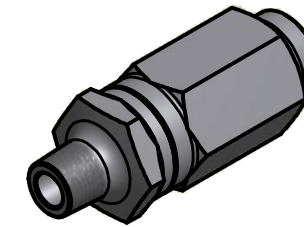

3/8" AUTOMATIC SPRING CHECK VALVE 1352 HAS BEEN APPROVED AS MEETING THE GRADE A HI-SHOCK REQUIREMENTS IN ACCORDANCE WITH MIL-S-901C(NAVY) ON THE BASIS OF LOCKHEED ELECTRONICS COMPANY TEST REPORT 1274-4407 DATED 9 SEPT. 1965 AND IS APPROVED FOR NAVAL USE BY NAVSEC LETTER 9510-SER 651E-1223 DATED 10 NOV. 1965

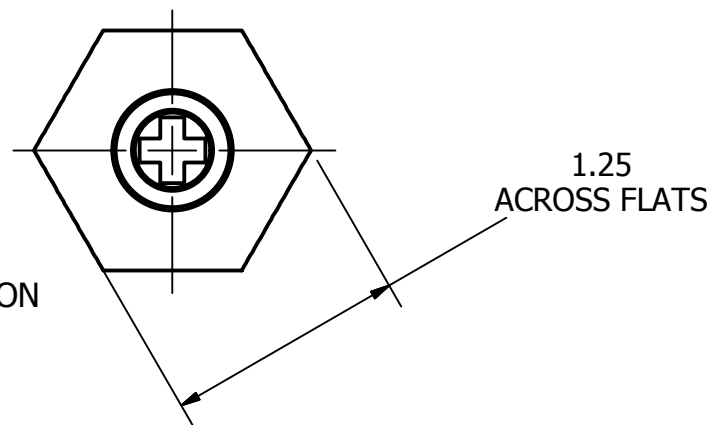

VALVE SHOWN IN CLOSED POSITION

Parts List				
ITEM	QTY	PART NUMBER	DESCRIPTION	MATERIAL
1	1	1-E-SS	VALVE BODY	STAINLESS STEEL
2	1	2-E-SS	VALVE COVER	STAINLESS STEEL
3	1	3-E-SS	STEM	STAINLESS STEEL
4	1	110-17	O-RING	SILICONE
5	1	4-E-SS	SPRING	INCONEL X750 ALLOY