

JEEP HOOD STYLE
RUBBER DRAW LATCHES
10 TOTAL, 3 ON EACH SIDE, 2 ON EACH END

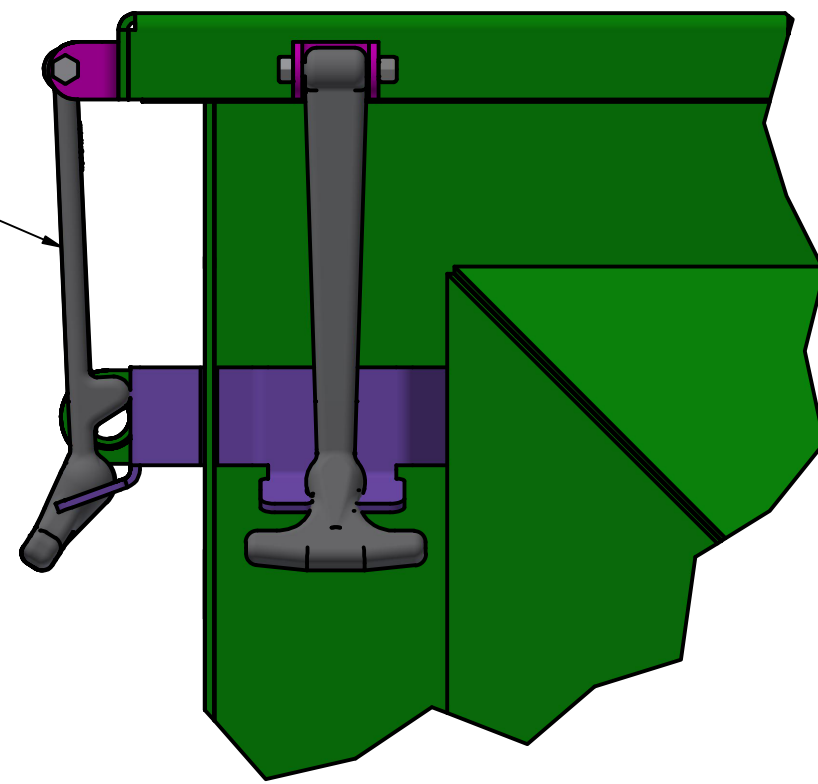

DETAIL B
SCALE .3

2- LID LIFTING HANDLES ON EACH END

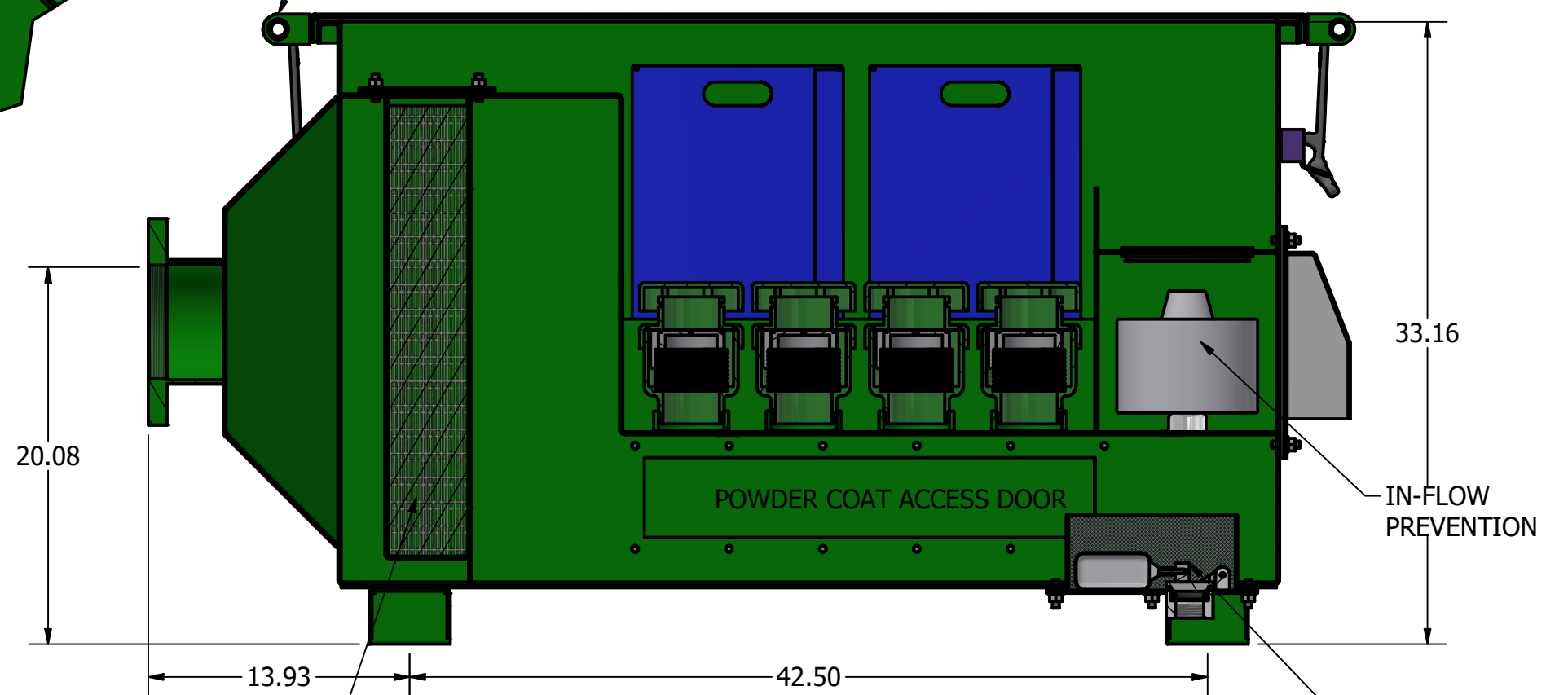

SECTION A-A
SCALE 0.12 : 1

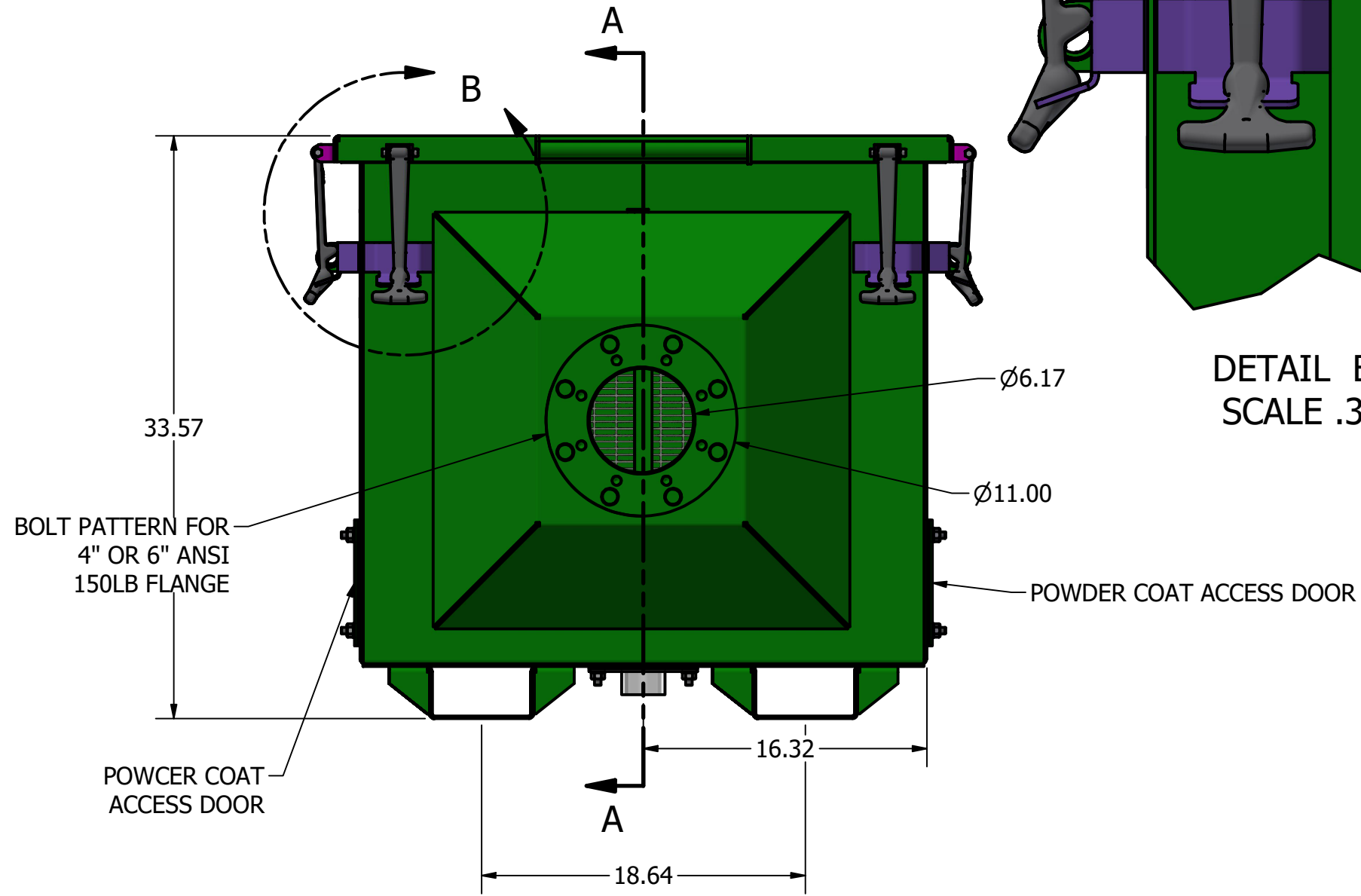

IN-FLOW
PREVENTION

FLOAT ACTUATED
DRAIN WITH
1.5-11.5 NPT
CONNECTION

MIST ELIMINATOR PAD

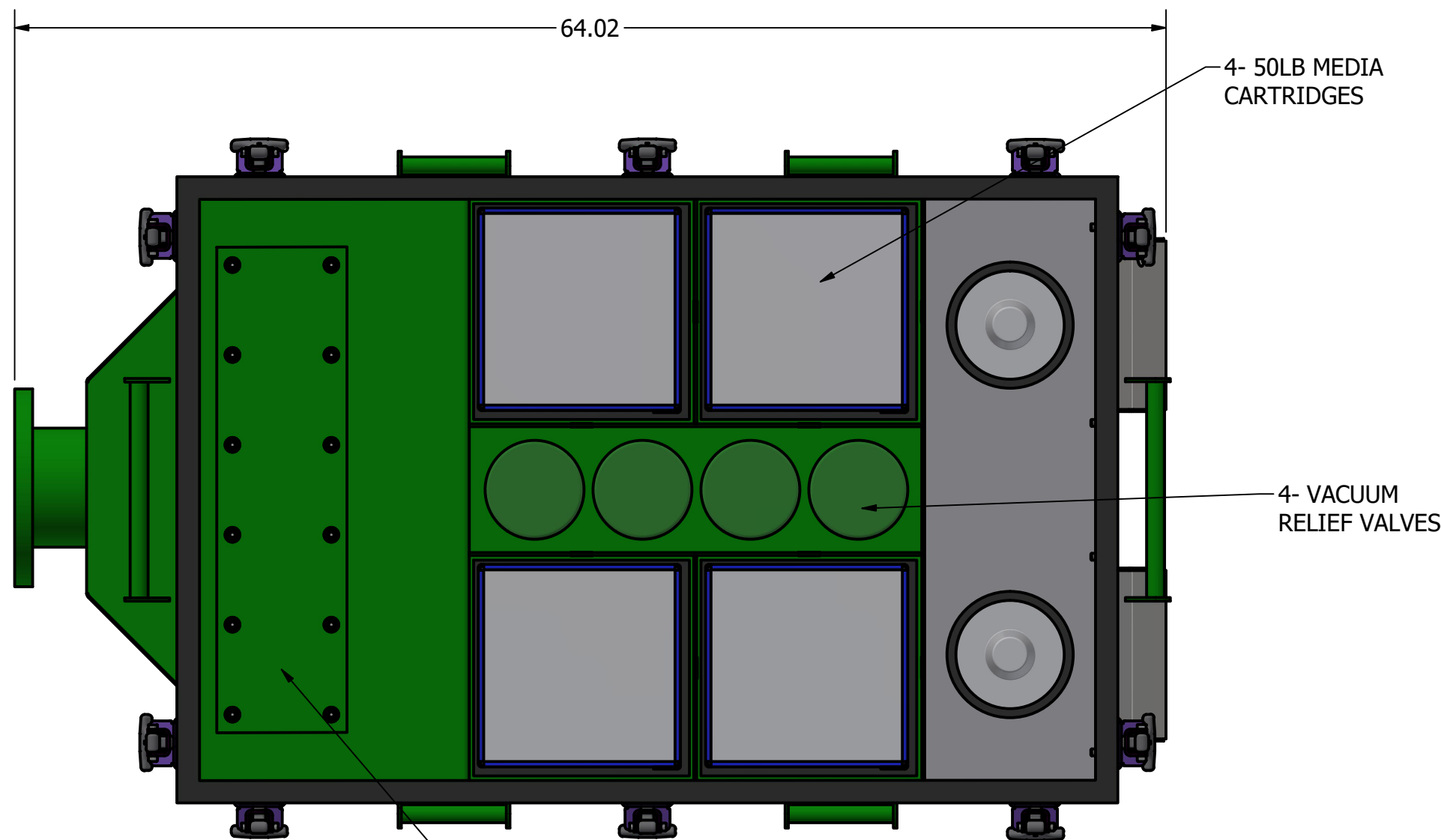

MIST ELIMINATOR PAD
ACCESS DOOR

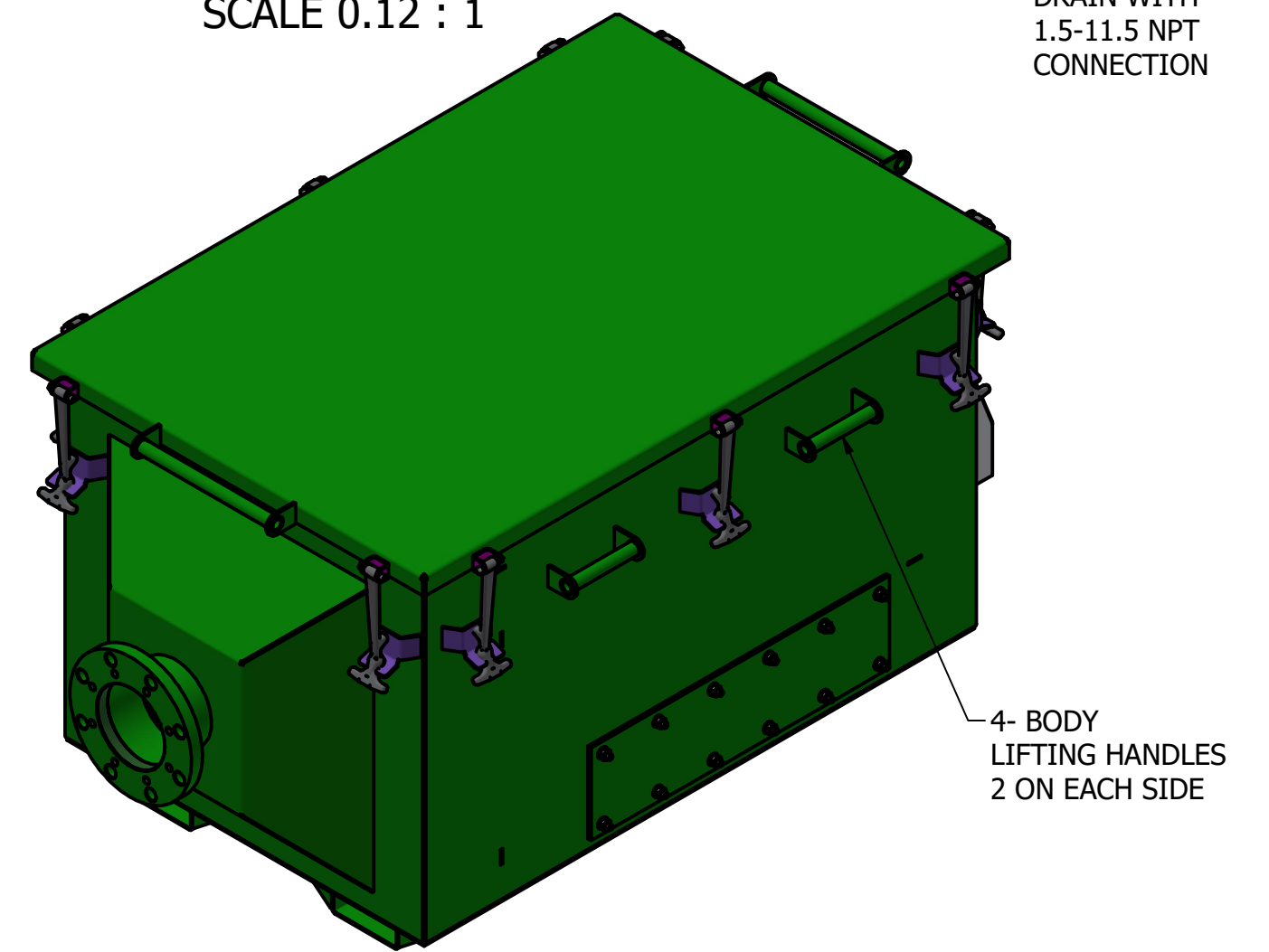

| | | | | |
|-----------------|----------|---------------------------------------|--------------|-----|
| DRAWN shardy | 2/5/2025 | ROBERT H. WAGER CO., INC. | | |
| CHECKED | | TITLE | | |
| QA | | 2050-200 FAPC, IWS, IN FLOW PREVENTER | | |
| MFG | | SIZE | DWG NO | REV |
| APPROVED | | C | 2050-200-IP | |
| | | SCALE | SHEET 1 OF 1 | |
| | | 0.12 : 1 | | |