

Robert H Wager Co., Inc.

570 Montroyal Road
Rural Hall, NC 27045
Ph: 800-562-7024
Fx: 336-969-6375
www.wagerusa.com

Parts List		
ITEM	QTY	PART NUMBER
1	1	BODY
2	1	STRAINER
3	3*	MOUNTING SCREW

* 6" Has (4) Mounting Screws

134 SERIES (STANDARD)
AVAILABLE IN FLANGED/
SLIP-ON OR WELD NECK
PLEASE SPECIFY WHEN ORDERING
3" AND 4" ONLY

134 Series (Standard)

When Ordering, Please Specify:
Threaded, Butt weld, Socket weld,
or Flanged.

Materials:

1020 Galvanized Steel or 316 Stainless Steel
356-T6 Anodized Aluminum Alloy (1.5"-3" Only, No 4")
835 Aluminum (1.5", 2" Only)

Standard Strainer is 3/8" thick Bronze (ASTM B62)
also available in 3/16", or 3/8" thick Stainless Steel (316),
and 3/8" thick Aluminum (T356-T6)

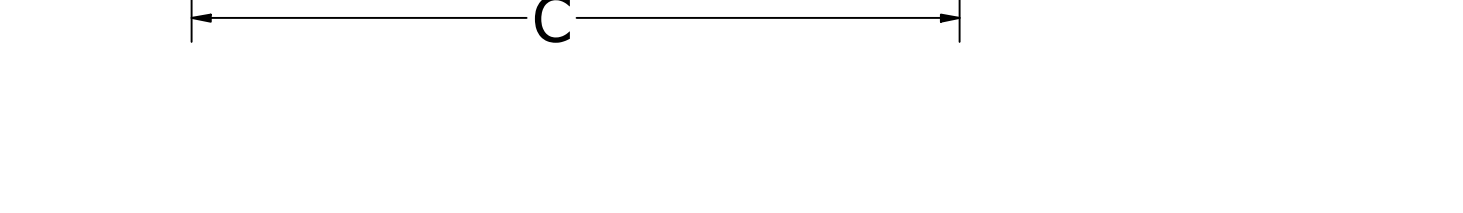
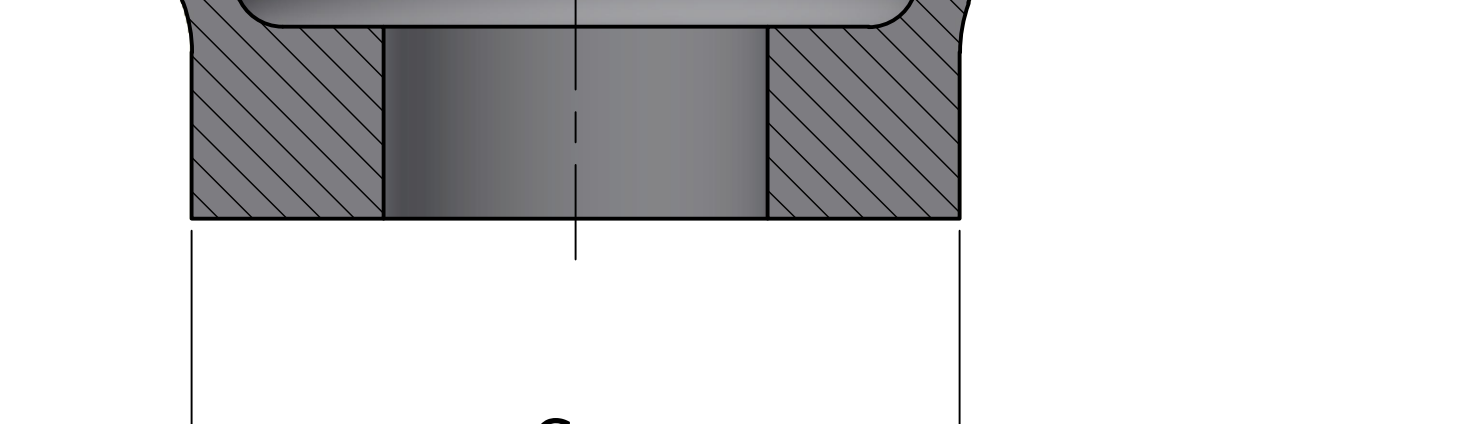
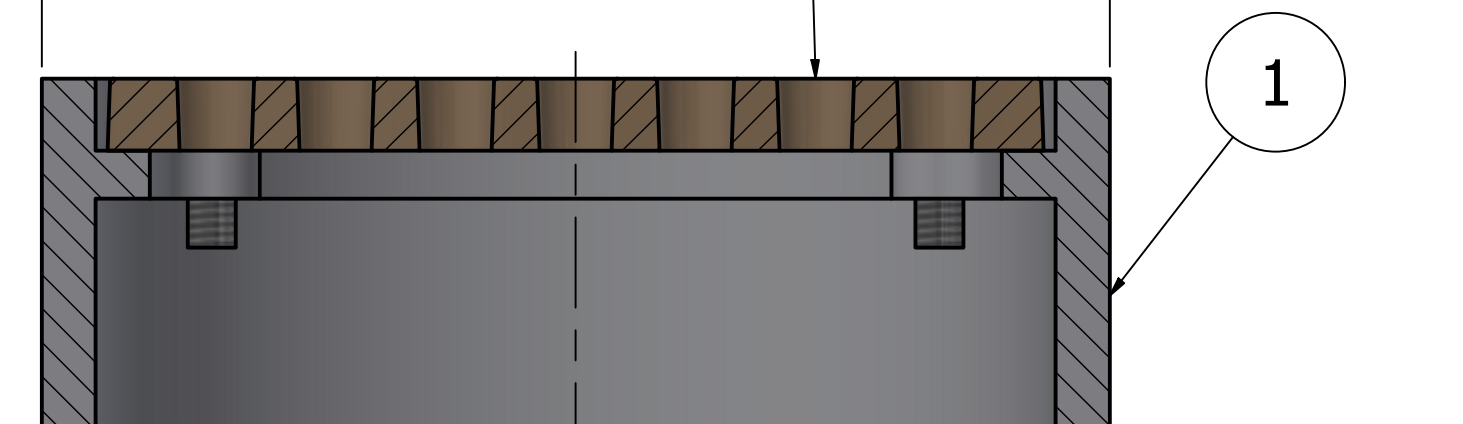
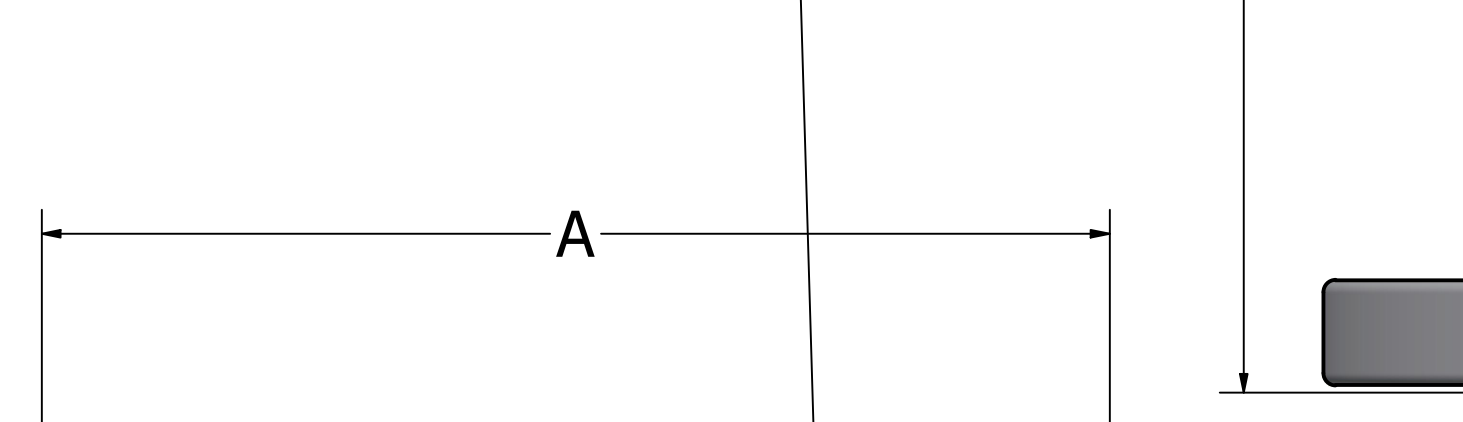
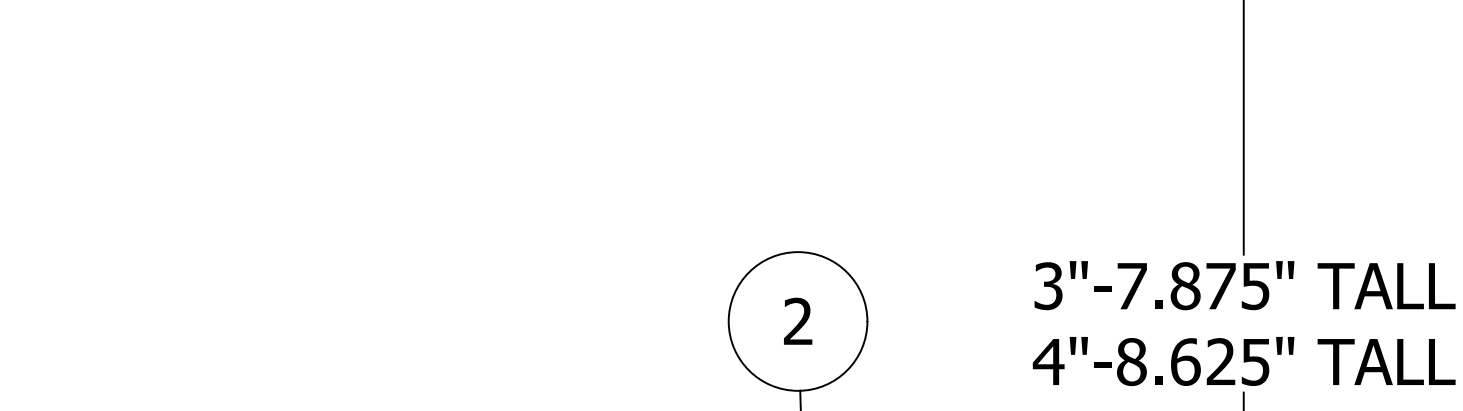
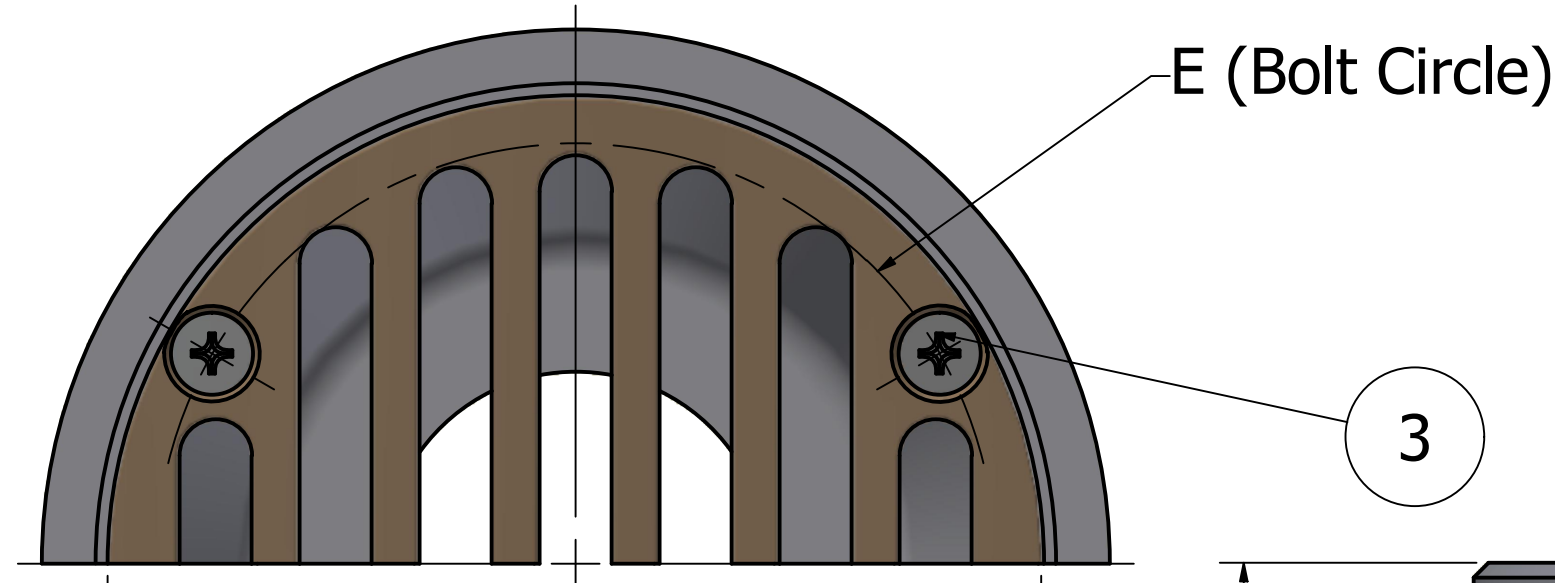

WELD NECK

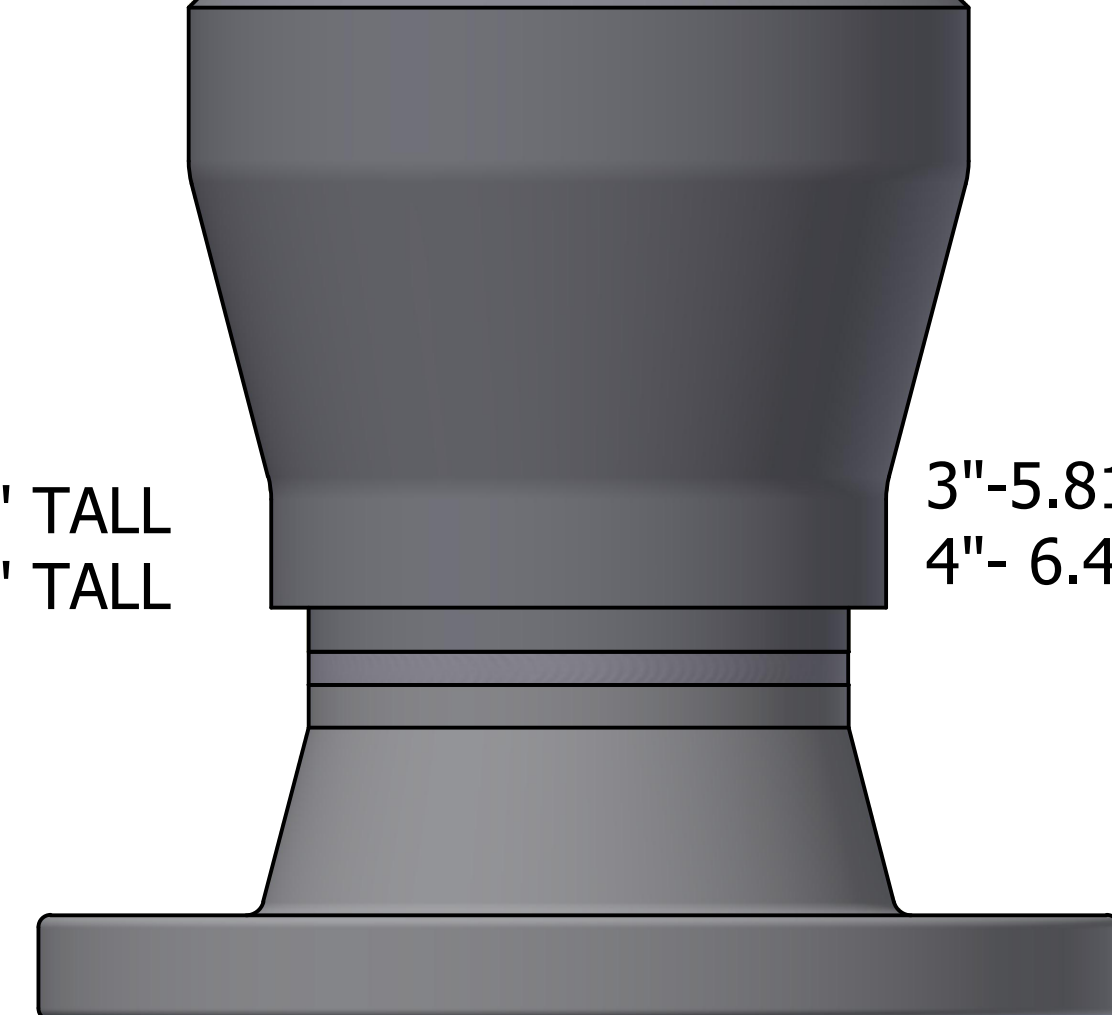

SLIP-ON

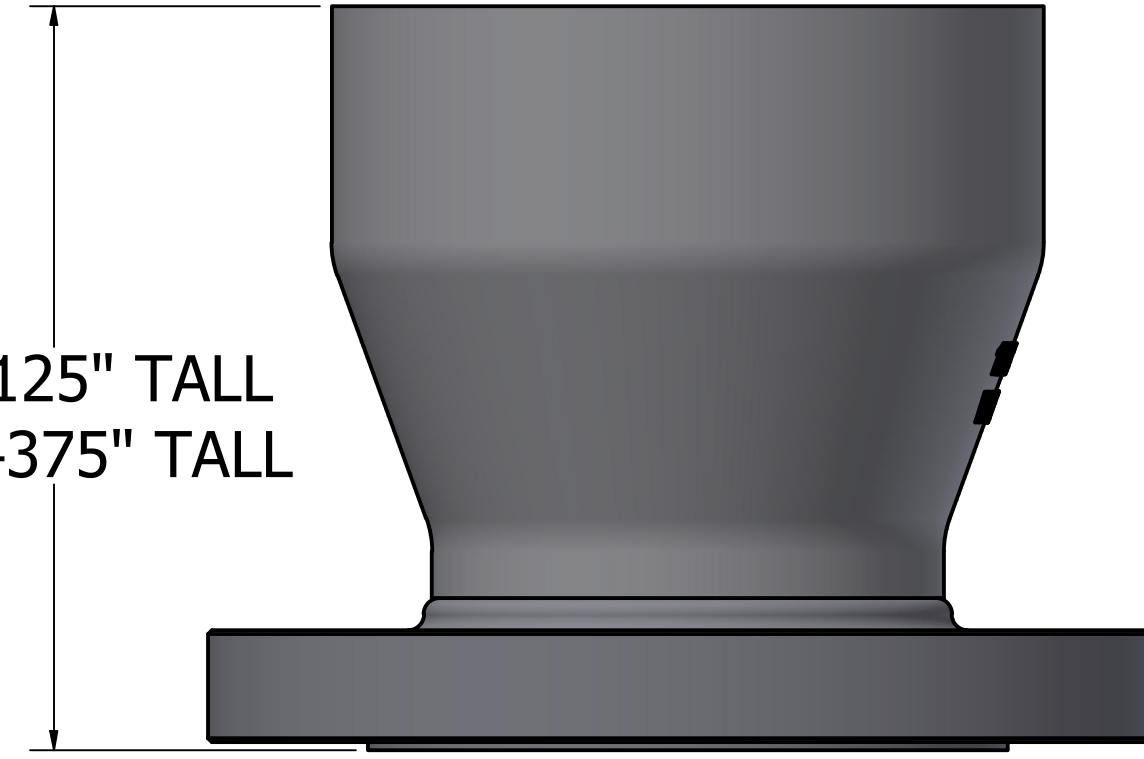

SIZE CHART

SIZE	A	B	C	D	E	F	OPEN AREA RATIO
.75-1-1.25	4.5	3.875	2.375	4.25	3.375	1.250	7.6/4.7/2.7 to 1
1.5-2	4.5	3.875	2.875	4.25	3.375	1.250	2.0/1.3 to 1
2.5	5.5625	4.875	4	5.125	4.375	1.985	1.7 to 1
3	5.5625	4.875	4	5.125	4.375	1.985	1.2 to 1
4	6.5	5.875	5.125	5.75	5.25	1.625	1.0 to 1
6	11.750	10.875	7.5	5.875	10	1.685	1.3 to 1

136 Series (2:1 RATIO)

Material: 1020 Galvanized Steel w/Bronze Strainer

SIZE CHART

SIZE	A	B	C	D	E	F	OPEN AREA RATIO
1.5-2	5.5625	4.875	4	5.125	4.375	1.985	2.6 to 1
2.5-3	6.5	5.875	5.125	5.75	5.25	1.625	2.0 to 1
4	11.750	10.875	7.5	5.875	10	1.685	2.9 to 1

