

Robert H. Wager Co., Inc.

570 Montroyal Road
 Rural Hall, NC 27045
 Ph: 800-562-7024
 Fx: 336-969-6375
 www.wagerusa.com

ANTI-SYPHONIC VALVE

1.5" NPT MALE THREADED ANTI-SYPHON VALVE

MATERIAL - CAST BRONZE (BODY)

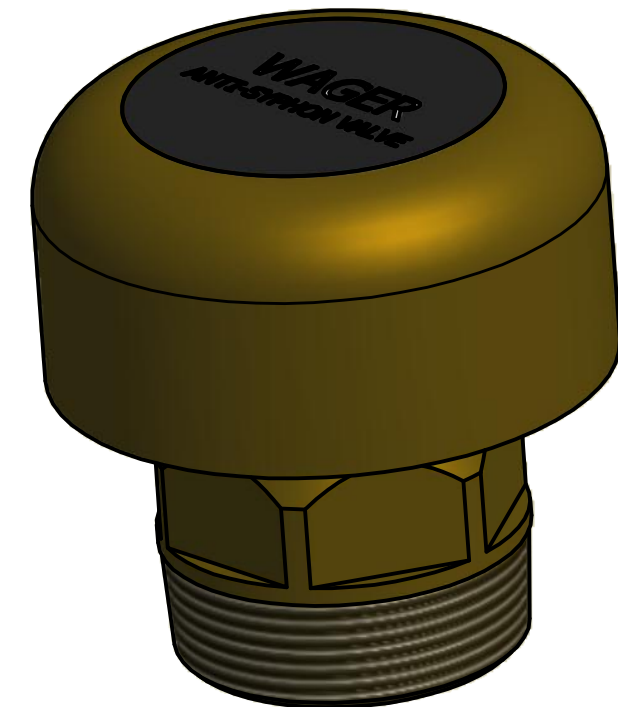
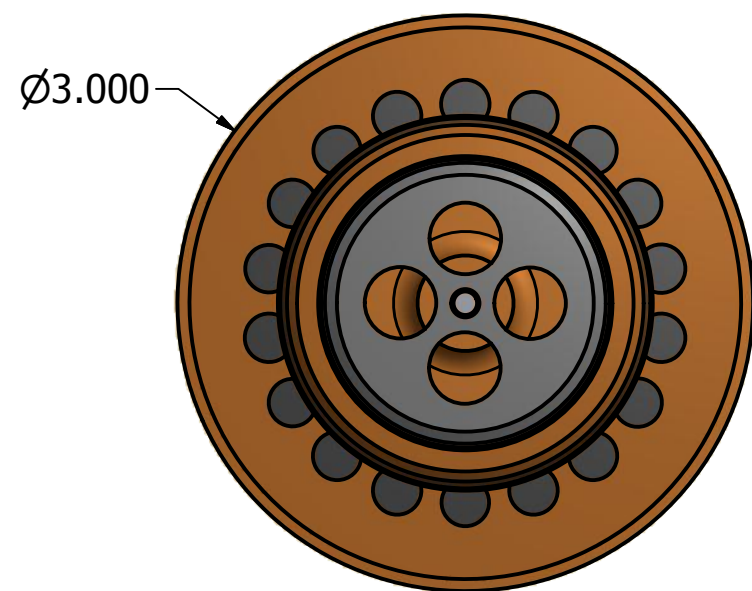
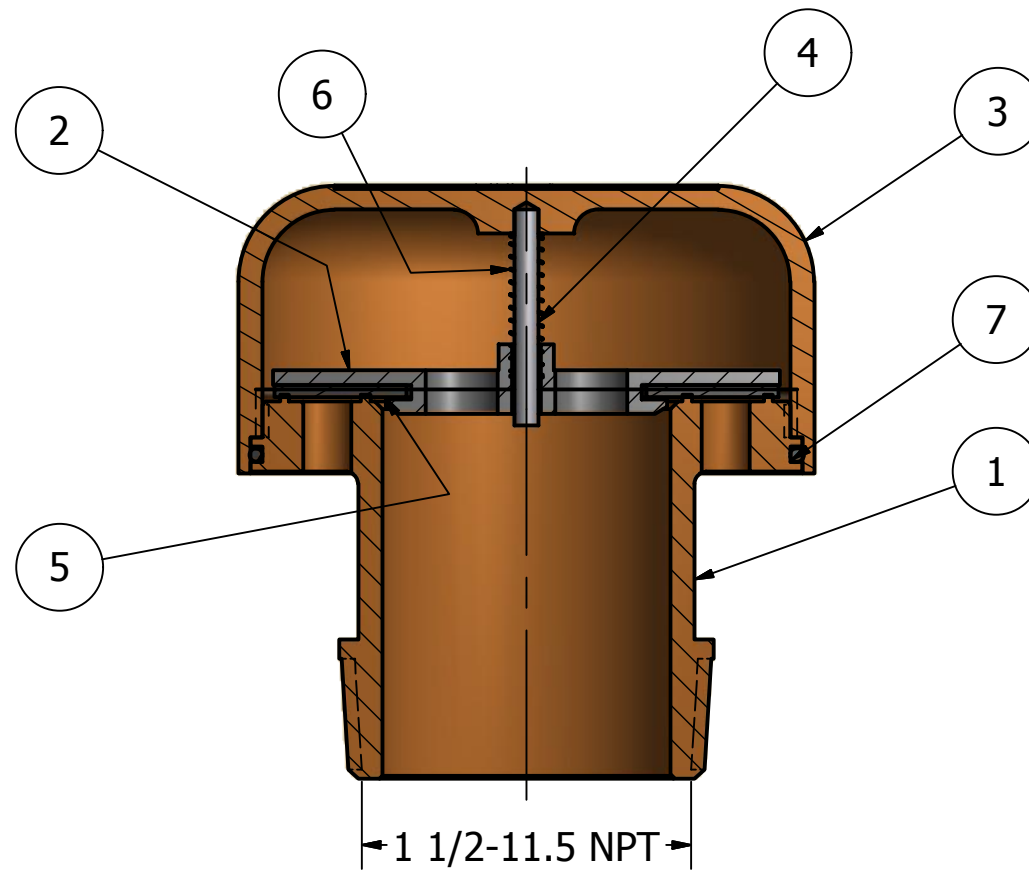
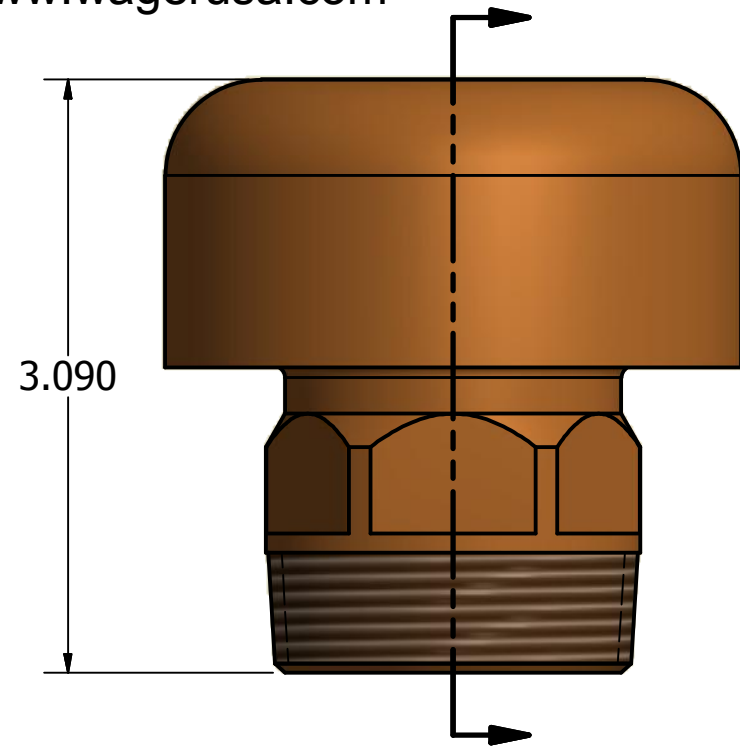

Parts List			
ITEM	QTY	PART NUMBER	NAME OF PART
1	1	AS-1.5-BASE	BASE
2	1	AS-1.5-D	DISC
3	1	AS-1.5-CAP	CAP
4	1	AS-1.5-SG	SPRING GUIDE
5	1	AS-1.5-G	GASKET
6	1	70252S	SPRING
7	1	AS-1.5-O	O-RING